



**ABSOLUTE OZONE®**

WWW.ABSOLUTEZONE.COM

---

**NANO® ATLAS® TITAN® MAGNUM®  
OZONE GENERATOR**

# **Operator's Manual**



---

**CONTACT**

Phone: +1 780-486-3761  
Toll Free: 1-800-488-8565  
E-mail: [office@absoluteozone.com](mailto:office@absoluteozone.com)  
Address: 10712-181 ST NW, Edmonton,  
Alberta, Canada  
T5S1K8

# TABLE OF CONTENTS

|           |                                      |    |
|-----------|--------------------------------------|----|
| Section 1 | General Information                  | 4  |
| 1A.       | Description                          | 5  |
| 1B.       | Specifications                       | 6  |
| 1C.       | Accessories                          | 7  |
| 1C.i      | Required Accessories                 | 7  |
| 1C.ii     | Recommended Accessories              | 8  |
| Section 2 | Installation                         | 10 |
| 2A.       | Location                             | 10 |
| 2B.       | Electrical                           | 12 |
| 2C.       | Plumbing                             | 12 |
| 2D.       | Typical Installation Diagram         | 13 |
| 2E.       | Gas Connections                      | 14 |
| 2F.       | Remote Control                       | 14 |
| Section 3 | Operation                            | 16 |
| 3A.       | LCD Control Panel Overview           | 16 |
| 3B.       | System Startup                       | 17 |
| 3C.       | System Shutdown                      | 17 |
| 3D.       | Standard Operating Procedures        | 18 |
| Section 4 | Maintenance and Service              | 19 |
| 4A.       | Preventative Maintenance             | 19 |
| 4B.       | Troubleshooting                      | 19 |
| 4C.       | iOZONE™ Diagnostic/Control system    | 21 |
| Section 5 | Ozone Overview and Safety Procedures | 24 |
| 5A.       | General Information                  | 24 |
| 5A.i.     | Relative strength of ozone           | 24 |
| 5A.ii.    | Micro-flocculation and oxidation     | 24 |
| 5B.       | General security information         | 25 |
| 5B.i.     | Ozone Properties                     | 25 |
| 5B.ii.    | Ozone Uses                           | 25 |

|   |    |
|---|----|
| 5C. Hazards                               | 26 |
| 5C.i. Health Hazards Detection            | 26 |
| 5C.ii. Effects on Humans                  | 26 |
| 5C.iii. Electrical Hazards                | 27 |
| 5C.iv. Fire Hazards                       | 27 |
| 5C.v. Chemical Action                     | 27 |
| 5D. Precautions for Safe Handling and Use | 28 |
| 5D.i. Ozone Monitors                      | 28 |
| 5D.ii. Ventilation                        | 28 |
| 5D.iii. Emergency Procedure               | 28 |
| 5D.iv. Respiration Protection             | 28 |
| 5D.v. Education and Training              | 29 |
| 5E. System Operations and Maintenance     | 30 |
| 5E.i. Safety Precautions Equipment        | 30 |
| 5E.ii. Maintenance Requirements           | 30 |
| 5E.iii. Monitoring Equipment              | 30 |
| 5F. First Aid Procedures                  | 31 |
| 5F.i General Information                  | 31 |
| 5F.ii Inhalation                          | 31 |
| 5F.iii Eye Contact                        | 31 |
| 5F.iv Precautions                         | 32 |
| 5F.v Emergency Information Form           | 32 |
| Section 6 Ozone Limited Warranty          | 33 |
| Section 7 Dimensions                      | 34 |

# 1. GENERAL INFORMATION

## IMPORTANT SAFETY INSTRUCTIONS - PLEASE READ CAREFULLY BELOW AND FOLLOW ALL INSTRUCTIONS



Read this manual completely before attempting installation and operation. Failure to install in accordance with the installation instructions could void warranty and result in injury or death.



All permanent electrical connections should be made by a qualified electrician.



**WARNING:** Short-term inhalation of high concentrations of ozone and long term inhalation of low concentrations of ozone can cause serious harmful physiological effects DO NOT inhale ozone gas produced by this device



**WARNING:** Only trained and authorized personnel should operate or handle this equipment.



**WARNING:** If unit is not operated according to instructions, high dosages of harmful substances may potentially be released



**WARNING:** High voltage is present inside the enclosure



**DANGER:** ELECTRICAL SHOCK HAZARD

Be sure to turn power OFF and disconnect from power source before any service work is performed. Failure to do so could result in serious injury or death

## USE EXTREME CAUTION

- Operate the generator with safe access to electrical power
- Connect to a GFCI type receptacle
- Follow all applicable electrical codes
- Do not bury chord
- To reduce the risk of electrical shock, please ensure to replace the damaged electrical chord immediately

## 1A. Description

Absolute Ozone® ozone generator cell design is based on proprietary Microfluidic Platform technology, constructed from ozone-resistant materials, and offers extremely high performance and reliability. The ozone cell is designed to be absolutely maintenance and service-free. The anticipated service life is 15-20 years.

Absolute Ozone® are modular generators that can be assembled into systems from 15 g/h to up to 5 kg/h ozone production. Absolute Ozone® generators produce ozone at higher concentration as specified in the performance test report supplied with every unit. Absolute Ozone® Ozone generators are designed to produce ozone for a variety of applications such as, but not limited to:

- Water Disinfection for Bottled Water Plants, Medical & Pharmaceutical Facilities, Swimming Pools, etc.
- Industrial Processes, Chemical production, Laboratories, Electronic Production, Mining, etc.
- Aquatic Life Support Systems for Marine Mammals, Fish Hatcheries, and Large Aquarium.
- Food Processing, Food Processing Facilities Disinfection, Food Preservation.
- Soil Remediation, Ground Water Remediation.
- Wineries Facilities Disinfection, Barrel Disinfection.
- Cooling Towers Water Treatment, Technological Processes Water Treatment.
- Potable Water Disinfection for Small Communities.
- Waste Water Treatment for Industrial Plants, Technological Production Processes, Commercial Facilities Waste Water Treatment, Dangerous Chemical and Bacteria Treatment, etc.

# 1. GENERAL INFORMATION

## 1B. Specifications.

| MODEL                    | OZONE PROD. (G/H) | WORKING PRESS. (PSIG) | OZONE CONC. (% W/W) | POWER OPTIONS  |
|--------------------------|-------------------|-----------------------|---------------------|--|
| NANO 15                  | 15                | 20                    | 5-10                | 120V ~10%, 50/60Hz, 2.6A<br>230V ~10%, 50/60Hz, 1.4A<br>Max. Power Cons: 200W  |
| ATLAS 30 /<br>TITAN 30   | 30                | 20                    | 9-12                | 120V ~10%, 50/60Hz, 5.6A<br>230V ~10%, 50/60Hz, 3.0A<br>Max. Power Cons: 500W  |
| ATLAS 30C /<br>TITAN 30C | 30                | 20                    | 9-16                | 120V ~10%, 50/60Hz, 5.6A<br>230V ~10%, 50/60Hz, 3.0A<br>Max. Power Cons: 500W  |
| ATLAS UHC /<br>TITAN UHC | 20                | 20                    | 9-22                | 120V ~10%, 50/60Hz, 4.0A<br>230V ~10%, 50/60Hz, 2.1A<br>Max. Power Cons: 350W  |
| ATLAS 60<br>TITAN 60     | 60                | 25-40                 | 6-12                | 120V ~10%, 50/60Hz, 7.0A<br>230V ~10%, 50/60Hz, 3.7A<br>Max. Power Cons: 700 W |
| ATLAS 60LP<br>TITAN 60LP | 20                | 20                    | 6-12                | 120V ~10%, 50/60Hz, 7.0A<br>230V ~10%, 50/60Hz, 3.7A<br>Max. Power Cons: 700 W |
| ATLAS 80<br>TITAN 80     | 80                | 25-40                 | 5-12                | 120V ~10%, 50/60Hz, 9.0A<br>230V ~10%, 50/60Hz, 4.7A<br>Max. Power Cons: 770W  |
| ATLAS 100<br>TITAN 100   | 100               | 30-50                 | 5-12                | 120V ~10%, 50/60Hz, 11A<br>230V ~10%, 50/60Hz, 5.8A<br>Max. Power Cons: 900W   |
| MAGNUM 120LP             | 120               | 20                    | 6-12                | 230V ~10%, 50/60 Hz, 7.3A<br>Max. Power Cons: 1300W                            |
| MAGNUM 160               | 160               | 30-50                 | 6-12                | 230V ~10%, 50/60 Hz, 9.4A<br>Max. Power Cons: 1540W                            |
| MAGNUM 200               | 200               | 30-50                 | 6-12                | 230V ~10%, 50/60 Hz, 11.5A<br>Max. Power Cons: 1800W                           |

## 1C. Accessories

Absolute Ozone® ozone generators could be used with several accessories and safety devices to ensure a long service life of the ozone generator.

### 1Ci. Required Equipment and Accessories

- **Oxygen Source**

**Generator/Concentrator:** This device separates oxygen from nitrogen and supplies it directly to the ozone generating cell. It utilizes a Pressure Swing Adsorption (PSA) molecular sieve bed to purify air by removing impurities such as dirt, moisture, nitrogen, and other trace gases. This process results in oxygen production with a purity greater than 90% and a dew point lower than -60°C.

Typically, an air compressor is required to pump ambient air into the oxygen generator, along with an air treatment system to ensure optimal performance by removing contaminants and moisture from the compressed air.

The generated oxygen is directed into the ozone generator cell, enhancing the ozone generation process. The ozone concentration produced can reach up to 23% by weight, depending on the oxygen flow rate and the type of generator used. Based on our experience, oxygen generators from AirSep have proven to be highly effective when used with Absolute Ozone® ozone generators.



**Warning on the Use of LOX (Liquid Oxygen):** Liquid Oxygen is a highly flammable liquid. Oxygen is the oxidizing agent in most fires and Liquid Oxygen is extremely likely to cause combustion of any inflammable material that it is in contact with.

When Liquid Oxygen (LOX) is used (evaporated) to feed the Ozone generators, make sure that the LOX system is in good working condition and take special precautions to prevent LOX from entering the Ozone Generator.

## 1Cii. Recommended Equipment and Accessories

- **Ozone Flow Control Valve (Flow Meter):** This component should be installed downstream of the ozone generator to maintain the working pressure across the ozone cell, as specified for optimal performance. It is essential that the flow control valve is ozone-resistant to ensure durability and reliable operation in the ozone environment
- **Oxygen Filter:** To safeguard the Absolute Ozone® generator from sieve particles in the event of an oxygen generator failure or malfunction, it is recommended to install an oxygen filter between the oxygen generator and the ozone generator. This precaution ensures that any contaminants are removed, maintaining optimal performance and extending the lifespan of the ozone generator.
- **ALD 2000FPD Flood Prevention Device:** We recommend installing an ALD 2000FPD with every ozone system treating water to prevent water from backing up into the ozone generator and causing damage. Non-return (check) valves do not offer complete protection against water flooding the ozone generator. Therefore, it is crucial to equip the ozone generator with the ALD 2000FPD or a similar device when treating liquids. This device enhances the safety and longevity of the ozone generator by providing an additional layer of protection against potential water ingress.
- **Ozone Injector for Water Treatment Applications (Venturi):** The ozone injector operates by utilizing the Venturi effect, This design creates a vacuum that effectively draws ozone gas from the ozone generator into the water stream. The injector is engineered to ensure that at least 90% of the ozone gas is continuously dissolved into the water flow, maximizing the efficiency of the ozone treatment process. This effective integration of ozone into the water is essential for optimizing disinfection and oxidation reactions in water treatment applications.



- **Ozone Degas Tank:** Ozone-enriched water from the ozone injector flows into the degas chamber/tank, where a slow down of water flow by 2 min allows any undissolved ozone and oxygen gas to rise to the top and be vented through a bleed-off valve ALD2000R to the outside or through an ozone destructor
- **Ozone Destructor:** Undissolved ozone gas passes through the regular or heated catalytic ozone destructor that is made up of non-consumable manganese dioxide (heat-protected from moisture fouling in heated destructor). The manganese dioxide offers redundant ozone destruct capabilities if selected and sized correctly.
- **Bleed-Off Valve ALD2000R:** The ALD2000R Bleed-Off Valve is specifically designed for use in contact tanks to facilitate the safe release of degassed ozone. This valve allows excess ozone to exit the tank, preventing the accumulation of gas that could lead to pressure build-up.
- **Ozone Sensors and Monitors:** Ozone sensors and monitors are valuable alternatives for enhancing the safety and efficiency of ozone treatment systems. These devices provide real-time measurement of ozone concentration levels in both gas and liquid phases, helping operators optimize performance. With advanced technology, ozone monitors deliver high accuracy and sensitivity, allowing for timely detection of ozone levels that may exceed safe thresholds.

In addition to monitoring, these devices can be integrated with control systems to automatically adjust ozone generation based on real-time readings, ensuring consistent treatment efficacy. By incorporating ozone sensors and monitors into your system, operators can improve reliability and ensure compliance with safety standards in water and air treatment applications.

## 2. INSTALLATION

### 2A. Location

Ozone Generator installation should allow for good access to proper electrical power and required gas connections and allow good cooling air circulation for the Ozone Generator(s).

**DO NOT OBSTRUCT COOLING AIR VENTS ON THE OZONE GENERATOR.**

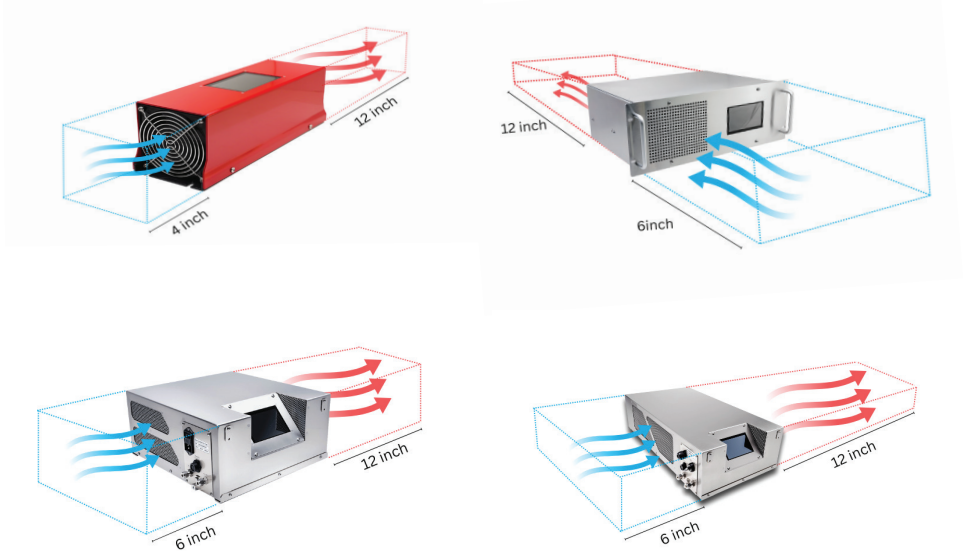

Absolute Ozone® generators should be installed in a dry, cool space shielded from weather conditions. The storage temperature ranges from  $-30^{\circ}\text{C}$  to  $50^{\circ}\text{C}$ . For optimal performance, the recommended operating temperature should be maintained between  $5^{\circ}\text{C}$  to  $24^{\circ}\text{C}$ .

**Note:** The ozone generators can be installed even hundreds of meters away from the point of use. This flexibility is particularly useful for placing the generator in a cool and dry location, which can enhance the performance and longevity of the equipment.

## Reversible Universal Mounting Flange

The NANO/ATLAS/MAGNUM® Ozone Generators have a universal mounting design to be installed on a vertical wall, on a horizontal or tilted bench, mobile cart or skied. TITAN® enclosure is designed for a 19" electronic mount rack.

For Benchmount Installation



For wallmount Installation



## Reversible Control Panel

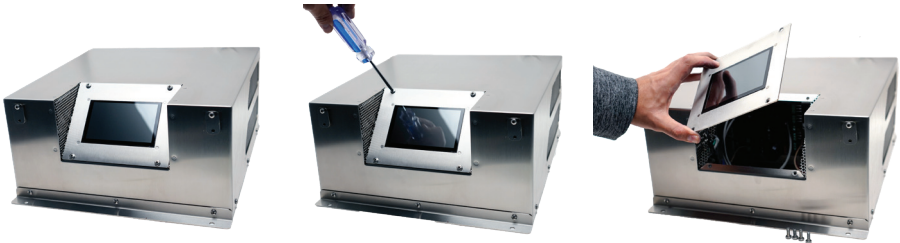

- **Starting Position:** The control panel is in the upright position (for benchmount installations).
- **Remove Screws:** Unscrew the 4 screws securing the control panel.
- **Rotate the Panel:** Rotate the control panel 180 degrees to switch to the downright position (for wall mount installations).
- **Secure the Panel:** Reinsert and tighten the 4 screws to secure the panel in its new position.

The **ATLAS/MAGNUM** is now ready to be installed in the wall mount position.

\*Be careful to not disconnect LCD wires when reversing control panel

## 2. INSTALLATION

### Stackable Without Rack

ATLAS/MAGNUM® ozone generator comes equipped with attachment tabs that can be reversed to provide you with the liberty to install the generator one on top of another in a rack mount formation but without requiring a rack.



### 2B. Electrical

**Main Power Supply Circuit:** Generators are supplied with a 3-5 feet power cord. Connect the power cord to a standard grounded power source, according to a local electrical code only.

### 2C. Plumbing

When injecting Ozone into the water, all measures should be taken to protect the Generator Cell from water exposure/flooding, which may cause internal cell damage. An ALD2000FPD or similar automatic liquid drain system is recommended to be installed on the ozone line to Venturi to prevent water flooding.

## 2D. Typical Installation Diagram

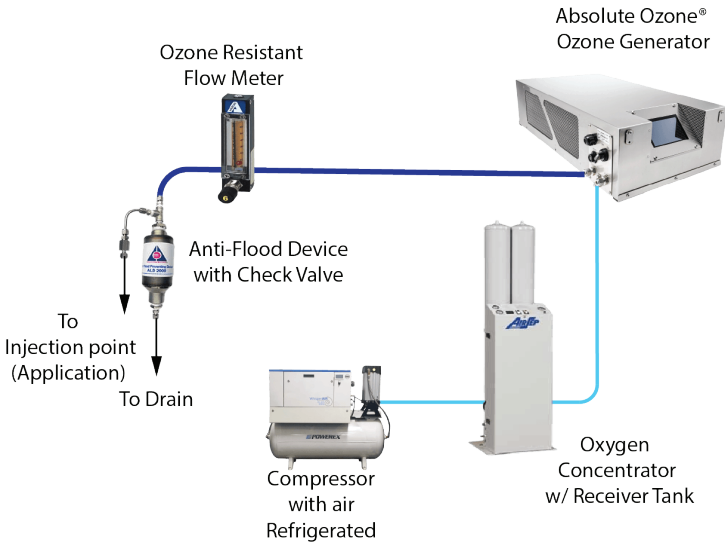
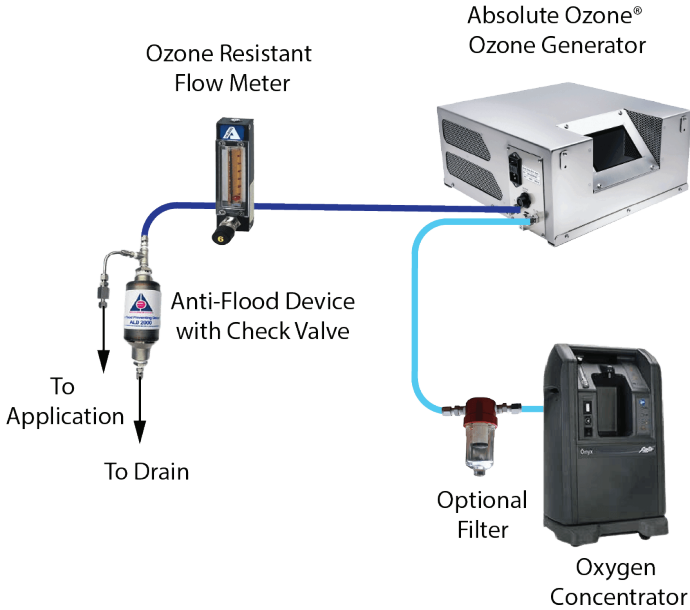

**Note:** The installation may vary depending on the specific application. Please contact us if you need assistance with the installation for your particular application.

## 2. INSTALLATION

### 2E. Gas Connections

The Ozone Generator should be connected by tubing made from material appropriate for ozone and oxygen applications. Connect the Ozone Generator according to indications on input and output bulkheads. All efforts should be made to protect the generator from exposure to incorrect operating gas pressure or excessive pressure fluctuations, which may lead to damage to electronic circuitry and the ozone cell. For applications where pressure fluctuations are possible, we strongly recommend the installation of a buffer tank with an appropriate hi-low pressure switch. It is **VERY IMPORTANT** to protect the Ozone Generator from any possible contamination from the oxygen concentrator or ozone injection side by installing appropriate filters and other contamination restricting devices upstream/downstream from the generator. Compressed air supplied to the oxygen concentrator should be free of oil vapors.

### 2F. Remote Control

All Absolute Ozone® generators are equipped with connectors for 4-20mA remote power level control as a standard feature. These connectors allow you to install an external control system to adjust the power going to the ozone cell remotely. Once the external control system is set up, it will automatically maintain the required power level, even if there are minor deviations in voltage or pressure. Additionally, a 10ft cable with pre-soldered pins is included for easy installation.

Before connecting the Remote control follow these preparation steps to ensure proper operation and avoid errors.

**Step 1:** Ensure that the power to the PLC (Programmable Logic Controller) or the 4-20mA signal source is turned off.

**Step 2:** Connecting the Signal Cable

**Step 3:** Power On the Devices

**Step 4:** Set the Ozone Generator to Remote Control Mode

## 2F. Remote Control

### 4-20mA On/Off Power Remote Control

- Remote control of ozone production level can be achieved by 4-20mA. The function of this power control is not linear.
- Remote On/Off. The remote Switch must be normally open for the generator to be “On” and closed to stop the Ozone production.
- That switch has to be connected to dry contacts only (not connected to ground or connected to any voltage source AC or DC)
- Remote Ozone Generator status indicator.
  - a) During Normal Ozone generator operation. Pins 5 and 6 are normally open, pins 6 and 7 are normally closed.
  - b) If Remote Control Switch is Off or safety shutoff is activated the circuit between pins 5 & 6 will be closed and 6 & 7 open.

Remote Control Schematic

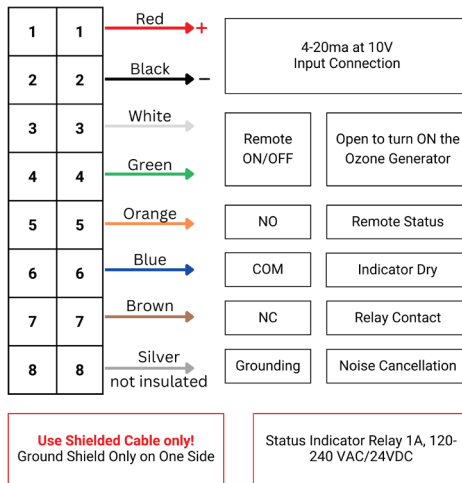

**Important:** To use the remote-control signal, set the local control on the display screen from (LCD) to (R/C) position.

**Attention!** At no time remote control cable’s shield should be connected to any other devices ground but the ozone generator #8 ground terminal.

# 3. OPERATION

## 3A. LCD Control Panel overview

The new LCD interface offers an intuitive and user-friendly experience, enhancing control and providing real-time data to help you manage the generator effectively.

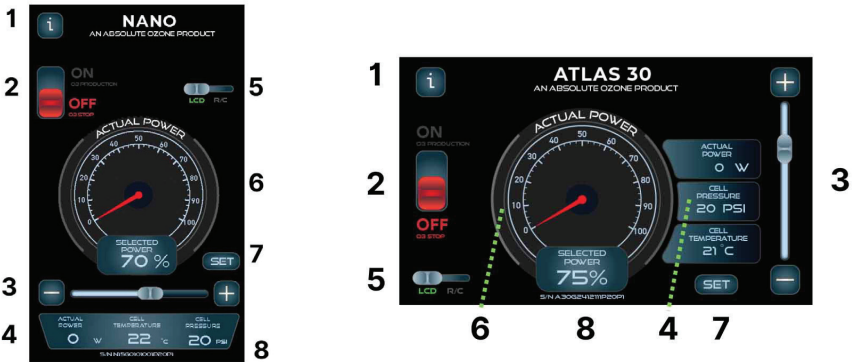

- 1. Information Button:** Accesses the information screen for troubleshooting, service diagnostics, and MFG setup.
- 2. ON/OFF Button:** Starts or stops ozone generation.
- 3. Increase/Decrease Buttons:** Adjust the ozone operational power.
- 4. Info Box:** This info box displays critical operational parameters for the generator
- 5. LCD R/C Switch:** Selects between direct or external control.
- 6. Power Dial:** Displays the current power level of the unit. The central number shows the selected power level.
- 7. SET Button:** Confirms the selected power level after adjustment using the numeric keypad. Pressing the "Set" button applies the change.
- 8. Serial Number:** Displays the unique identifier for the unit.



### **3B. System Startup**

1. Make sure the Ozone Generator enclosure is securely attached to an appropriate frame or wall
2. Make sure all connections to the generator, power, and gas are made according to local codes and regulations.
3. Before turning the generator ON, purge the generator with 90% or higher concentration of oxygen and ensure a free flow of oxygen through the system to remove contaminants. Conduct a system leak test using oxygen only, applying a working pressure of +/-10%. Adjust the gas pressure across the cell according to specifications using a downstream control valve (on the flow meter) and a pressure gauge (supplied by the installer).
4. Plug the system into a specified receptacle.
5. Flip the Power Switch into the "ON" position.
6. Slide the red dot on the power control slider upwards to adjust to desired power from 0-100% according to supplied "Ozone Generator Performance Test" chart. Now the generator is at optimum production mode, and ozone should be flowing through the system.

### **3C. System Shutdown**

1. Slide the red dot on the power control slider downwards to adjust power from 0%. (No ozone is produced at this time.)
2. Switch the power switch to the OFF position.
3. Unplug the system from the power source if required.
4. Close down the downstream Control Valve (located on the flow meter -supplied by the installer) to protect the unit from accidental flooding.
5. Turn the oxygen source off.

## 3. OPERATION

### 3D. System Standard Operating Procedures

To ensure a long trouble-free service life for the ozone Generator, provide the following operating conditions:

- Make sure that the oxygen concentrator is maintained properly and is producing oxygen at greater than 90% purity and less than -60°C dew point. Check sieve conditions and replace it as often as recommended by the manufacturer.
- Install an oxygen filter and oxygen dryer between the oxygen concentrator and the Ozone Generator, check the condition and replace the cartridge to protect Ozone Generator from sieve particles in case of oxygen generator failure and moisture.
- Make sure to maintain working pressure across ozone cells as specified for the generator protection and most efficient production.
- When injecting ozone into water, make sure to protect the generator from flooding by installing a device capable of preventing water backup. Check valves usually start leaking after a few days of operation in ozone and cause serious damage to the ozone cell. We recommend using devices which could automatically drain water out of the ozone line and stop it from entering the ozone cell.



**IMPORTANT:** When a system is OFF for an extended period, it is very important to prevent back flow of liquids and gases through the cell. Back flows void the cell warranty. For example, a system which uses a venturi and concentrator must contain a solenoid valve or other reliable means to block gas flow if it is possible that the venturi will be active while the concentrator is off.

## 4. MAINTENANCE AND SERVICE

### 4A. Preventative Maintenance

Generally, Absolute Ozone® is maintenance-free, although it is useful to check the Ozone Generator for proper operation:

1. Make sure there are no warnings on the LCD screen.
2. Inspect all gas, power and signal cables and connectors visually
3. Make sure that all air vents are not obstructed.

#### Monthly:

1. Make sure that all system equipment (oxygen concentrator, air compressor, etc.) is maintained according to the manufacturer.
2. Remove and replace or clean filter cartridges and other devices if installed and required.
3. Perform general cleaning of the cabinet exterior after disconnecting the equipment from the electrical source.
4. Using clean/dry compressed air or a vacuum cleaner, blow out the interior or vacuum the cabinet, taking special care around electronic components and wiring.

### 4B. Troubleshooting

Knowledge of electrical applications is required for troubleshooting. Contact a certified electrician if you are unsure of your ability to service the equipment. If any problem persists, please call +1 (780) 486-3761. We will have one of our system engineers discuss your situation with you over the phone.

## 4. MAINTENANCE AND SERVICE

### Ozone Leak Troubleshooting

#### Pressure Testing:

Ozone generators are tested at pressures up to 120 PSIG and are equipped with ozone-resistant seals, making it uncommon for leaks to occur. In most cases, any leaks that do arise are typically due to gas connections rather than the generator itself.

To accurately determine if a leak is originating from the ozone cell or another area, it is essential to isolate different components of the system and perform pressure tests. Follow these steps:

**Important:** Never perform pressure or leak tests while the generator is connected to power.

#### Preparation:

- Ensure the generator is powered off and disconnected from the electrical supply.
- Connect the oxygen supply to the system and adjust the pressure to between 20 and 120 PSIG, with 20 to 40 PSIG usually being sufficient for testing.

#### Isolate Components:

- Close the isolation valves of the various components you wish to test. This will help identify the source of the leak by isolating sections of the system.

#### Monitor for Pressure Drops:

- Record the initial pressure on the manometer and monitor for any drops over a period of 15 to 30 minutes.
- A significant pressure drop during this time may indicate a leak in the isolated section.

#### Detecting the Leak:

- Once isolated, spray 99% isopropyl or rubbing alcohol on connections and fittings. If there's a leak, bubbles or a hissing sound will indicate the source. Alcohol is safe for sensitive system components, making it an effective detection method.

### **Fixing Minor Leaks:**

If the leak is at a gas connection, ensure it is securely tightened. For leaks near the high-voltage electrode, tighten the electrode screw by about  $\frac{1}{4}$  turn.

**Disclaimer:** To avoid voiding the warranty, the ozone generator should only be opened if authorized by Absolute Ozone.

## **4C. iOZONE Diagnostic/Control System**

Internal iOzone™ intelligent diagnostic/controller system protects Absolute Ozone® generators from the following potential problems:

- Incorrect wiring or voltage applied to the remote control terminals.
- Incorrect power applied in the specified range (too low, too high)
- Incorrect operating pressure.
- Ozone cell problem
- Bad feed gas quality (too much humidity or contamination)
- Overheating or failure of the cooling system, etc.

In the event that incorrect operating parameters are applied to the ozone generator the unit is switched off by the Ozone intelligent diagnostic control system, and the LCD screen will indicate which of the parameters caused the generator shutdown.

In a safety shutdown mode the generator will be constantly monitoring operating parameters and the moment they are corrected the generator will restart automatically, without any assistance.

# 4. MAINTENANCE AND SERVICE

## Symptom (Warning Message):

**WARNING!**  
E001 - HIGH VOLTAGE



Connected to incorrect voltage, please immediately disconnect the generator from power and do not power it up, unless specified voltage is applied

**WARNING!**  
E002 - LOW VOLTAGE



Connected to incorrect voltage, please immediately disconnect the generator from power and do not power it up, unless specified voltage is applied

**WARNING!**  
E003 - HIGH GAS PRESSURE



Please immediately power off the ozone generator, shutdown the oxygen gas supply line, adjust pressure regulator to specified operating pressure, re-establish correct gas flow and restart power to ozone generator.

**WARNING!**  
E004 - LOW GAS PRESSURE



Please make sure that correct operating gas pressure is supplied to the generator, and it will be able to produce ozone automatically.

**WARNING!**  
E005 - OZONE CELL TEMPERATURE IS TOO HIGH



Ozone cell temperature is too high; power is reduced to allow the cell to cool down for better ozone production.

**RESET**

**WARNING!**  
E006 - OZONE CELL PROBLEM



The ozone generator is off due to abnormal power consumption from cell contamination, or incorrect operating parameters. Pressing "Reset" will bypass safety but may cause cell damage not covered under warranty only push "reset" if sure that cell is not contaminated to restore safety features, reset the generator's power.

**RESET**

**WARNING!**  
E007 - REMOTE CONTROL VOLTAGE PROBLEM



Please verify that 4-20mA remote control signal is applied to correct terminals and that only control permissible signal voltage is applied; then reset power to the generator and start normal operation.

**RESET**

**WARNING!**  
E008 - POWER MEASUREMENT PROBLEM



Please refer to troubleshooting screen - Operator's Manual

**WARNING!**  
E009 - PRESSURE AND TEMPERATURE SENSOR PROBLEM



Please refer to troubleshooting screen - Operator's Manual

### SUPPLY VOLTAGE TOO HIGH OR TOO LOW:

Please make sure that the voltage supplied to the ozone generator is as specified +/- 5% in order to correct the problem. If the voltage supplied is as specified and the problem persists, please contact our service department

### OZONE CELL PRESSURE TOO HIGH

Please adjust the oxygen pressure regulator to the specified pressure and that will rectify this problem and warning message.

### OZONE CELL PRESSURE TOO LOW

Please make sure there are no restrictions on the oxygen line coming to the ozone generator and that the flow is only adjusted on the ozone line after the ozone generator to maintain the correct working pressure, if the pressure is too low due to an incorrectly set pressure regulator or failure of oxygen generators, please rectify the problem and the ozone generator will continue operation.

### **OZONE CELL TEMPERATURE TOO HIGH**

Make sure that the ambient temperature in the installation room is below 24°C, and check that there is good unrestricted cooling airflow through the ozone generator (not obstructed on either side of the cooling grills). Please make sure that the cooling fan is working properly. In case of the cooling fan failure, please contact technical support for further instructions

### **OZONE CELL PROBLEM**

The ozone generator is off due to abnormal power consumption from cell contamination or incorrect operating parameters. Pressing "Reset" will bypass safety but may cause cell damage not covered under warranty. Only push "reset" if you are sure that the cell is not contaminated and the operating parameters are correct. To restore safety features, reset the generator's power.

### **REMOTE CONTROL VOLTAGE PROBLEM**

Verify that a 4-20mA remote control signal is applied to the correct terminals and that only control permissible signal voltage is applied.

### **POWER MEASUREMENT PROBLEM**

The ozone generator detects a problem measuring power. Please restart the generator. If the problem persists, it may need to be sent for inspection and repair.

Temperature sensor, restart the generator. If the problem persists, the generator may need to be sent for inspection and repair.

Please immediately disconnect the generator from power and do not power it up unless the specified current is applied

### **PRESSURE/TEMPERATURE SENSOR PROBLEM**

If your ozone generator detects a problem with the pressure or temperature sensor, restart the generator. If the problem persists, the generator may need to be sent for inspection and repair.

## 5. OVERVIEW AND SAFETY PROCEDURES

### REMOTE CONTROL WIRING PROBLEM

The ozone generator detects an issue with the remote control wiring

### HIGH CURRENT

The generator is connected to an incorrect current, please immediately disconnect the generator from power and do not power it up unless the specified current is applied

## 5A. General Information

### 5Ai. Relative Strength of Ozone

The following compares the strengths of several common oxidizing reagents (EOP vs. Cl<sub>2</sub>)

- Elemental Fluorine (2.25)
- Hydroxyl Radical (2.05)
- Ozone (1.52)
- Hydrogen Peroxide (1.30)
- Hypochlorite (1.10)
- Chlorine (1.00)
- Chlorine Dioxide (0.93)
- Bromine (0.57)

### 5Aii. Micro-Flocculation and Oxidation

Ozone oxidizes the following metals (known as micro-flocculation), enabling their removal via filtration:

- Iron
- Copper
- Manganese
- Zinc
- Arsenic

Ozone neutralizes “nuisance” compounds - most commonly, hydrogen sulfide.



## 5B. General Safety Information

### 5Bi. Ozone Properties

- Colorless to blue gas (greater than -169 F).
- The characteristic odor is often associated with electrical sparks or lightning in concentrations of less than 0.02 ppm.
- Highly chemically reactive.
- Non-flammable, non-carcinogenic.
- Hazardous polymerization can occur in some rare materials.
- Spontaneously decomposes to oxygen gas.

### 5Bii. Ozone Uses

- Air and water disinfection
- Surface sanitation
- Water treatment plants
- Bottled water, irrigation, community water supplies, swimming pools/spas, etc.
- Aquariums/life support
- Agricultural wash water
- Wastewater treatment
- Mold and bacteria control in cold storage
- And more

## 5. OVERVIEW AND SAFETY PROCEDURES

### 5C. Hazards

#### 5Ci. Health Hazards Detection

Gaseous ozone can be detected in the air by its distinctive odor at concentrations of about 0.02 ppm. Although each nose varies, olfactory fatigue occurs quickly.

Initial small exposure may reduce cell sensitivity and/or increase mucous thickness, producing resistance to low gaseous ozone levels.

#### **DO NOT RELY ON ODOR AS A WARNING OF HIGH OZONE CONCENTRATIONS.**

The Permissible Exposure Level (PEL) or time-weighted concentration for gaseous ozone to which workers may be exposed is 0.1 ppm averaged over 8 hours, 5 days a week (OSHA)\*. The short-term exposure limit is 0.3 ppm averaged over 15 minutes. The concentration of 5.0 ppm ozone in the air is generally accepted as Immediately Dangerous to Life or Health (IDLH)\*.

#### 5Cii. Health Hazards Effect on Humans

Gaseous ozone acts as a primary irritant, affecting mainly the eyes, upper respiratory tract, and lungs. Inhalation produces various degrees of respiratory effects, from irritation to pulmonary edema (fluid in the lungs). Short exposure to 1-2 ppm concentrations causes headaches as well as irritation to the respiratory system but, symptoms subside when exposure ends. High concentrations of ozone produce severe irritation to the eyes and respiratory system. Exposure above the ACGIH/OSHA limits may produce nausea, chest pain, coughing, fatigue, reduced visual acuity, and pulmonary edema. Symptoms of edema from excessive exposure can be delayed one or more hours. There is no threshold limit, and so no exposure (regardless of how small) is theoretically without effect from ozone's strong oxidative ability.

\*Regulations regarding levels may vary from country to country."

### **5Ciii. Electrical Hazards**

Turn OFF all power switches and disconnect the power cord from the power source receptacle before performing service work. Failure to do so could result in serious injury or death.

Operate the generator with safe access to electrical power. Connect the generator to a G.F.C.I. Type receptacle or as required by local electrical codes & regulations. Do not bury the electrical cord. To reduce the risk of electrical shock, replace the damaged cord immediately.

### **5CiV. Fire Hazards**

Ozone is non-flammable. The decomposition of ozone into oxygen gas ( $O_2$ ) can increase the strength of fire. Ozone is unstable at room temperature and spontaneously decomposes to oxygen gas. Avoid ignition sources such as heat, sparks, and open flame. Keep away from strong combustible materials such as grease, oils, and fats.

### **5CV. Chemical Action**

Ozone is chemically incompatible with all oxidizable materials, both organic and inorganic.

## 5. OVERVIEW AND SAFETY PROCEDURES

### 5D. Precautions for Safe Handling and Use

#### 5Di. Ozone Monitors

Ambient ozone monitoring/control equipment (available from Absolute Ozone®) should be installed in the areas where ozone is being generated or applied. In a case when ambient ozone concentration reaches or becomes higher than 0.05 ppm, the ozone monitor/controller should switch the power of the ozone generator off and produce a warning audio/visible signal to allow people to clear the room and avoid high concentration ozone exposure.

#### 5Dii. Ventilation

It is mandatory that general and local exhaust ventilation be provided to dilute and disperse small amounts of ozone into the outside atmosphere. Federal, state, and local regulations must be followed.

#### 5Diii. Emergency Procedure

Due to the short life of ozone, evacuation and ventilation are all that are generally required in the event of a high ambient ozone alarm. All ozone-generating and delivery equipment should be shut down (manually or automatically by alarm), and a high-speed fan activated to dilute and disperse ozone into the atmosphere. Personnel should leave the affected area until levels are returned to below 0.1 ppm.

#### 5Div. Respiratory Protection

Disposable respirator (3M #N95 8214/8514 - Minneapolis, MN, [www.3m.com](http://www.3m.com)) is recommended for relief against ozone levels up to 10 times the OSHA PEL or applicable government occupational exposure limits, whichever is lower.

## 5Dv. Education and Training

The education and training of workers are the responsibility of the end user. An effective training program must be practical, based on written work procedures, and specific to both the job site and the tasks to be performed. Training shall also include the responsibilities and responses of workers in an emergency. The employer shall ensure through the education and training program that all workers can work without risk to themselves or others around them. All workers must clearly understand their responsibilities concerning not only specific work procedures but also the need to report all hazards, accidents, or incidents and injuries. Management and employees shall review all routine work and emergency procedures jointly at least once annually.

## Toxic Effect of Gaseous Ozone

| OZONE CONCENTRATION | EFFECT   |
|---------------------|--|
| 0.01 - 0.10 (PPM)   | Range of Odor Threshold. Headaches, irritation to respiratory tract, severe irritation to eyes |
| 0.1 (PPM)           | Permissible concentration (8 h work day)*  |
| 0.3 (PPM)           | Permitted short-term exposure (15min.)*  |
| 1.0-10.0 (PPM)      | Nausea, chest pain, coughing, fatigue, reduced visual acuity, pulmonary edema                  |
| 5.0 (PPM)           | Immediately Dangerous to Life or Health (I.D.L.H)*   |
| >20.0 (PPM)         | Can be fatal after 1 hour  |
| >50.0 (PPM)         | Can be fatal after 30 minutes  |

\*Regulations regarding levels may vary from country to country."

## 5. OVERVIEW AND SAFETY PROCEDURES

### 5E. Systems Operations and Maintenance

#### 5Ei. Safety Precautions and Equipment

Repair and maintenance of the ozone system shall be done under the direction of qualified personnel. Qualification shall consist of instruction from the equipment supplier on the safeguards and procedures necessary for the safe performance of the work. Repair of the Ozone Generator could be performed only under the supervision of Absolute Ozone® engineers unless authorized and instructed otherwise by Absolute Ozone personnel. All equipment in an ozone plant (ozone generator, piping, pumps, tanks, etc.) coming in contact with gases containing ozone must be maintained free of oil and grease. Monitoring equipment and alarm system shall be tested and serviced according to the manufacturer's instructions. The planned maintenance of all safety equipment is essential to worker safety.

#### 5Eii. Maintenance Requirements

It is the joint responsibility of the manufacturer, supplier, and installer of the Ozone generating and handling equipment to determine whether or not the system is working properly. The operation and maintenance manual provided with the equipment outlines the operating procedures and maintenance requirements.

#### 5Eiii. Monitoring Equipment and Location

Ambient ozone detection monitors shall be located to monitor ozone room air and production/plant room air for indoor applications.

Proper Ozone Monitoring equipment should be used to protect personnel from dangerous levels of ozone exposure.

Absolute Ozone® could provide suitable ozone monitoring at customer request.

## **5F. First Aid Procedure**

### **5Fi. General Information**

1. DO NOT PANIC. If exposure to gaseous ozone causes headaches or shortness of breath, immediately remove the worker to a fresh-air environment.
2. Ensure there is no more danger to yourself or the worker.
3. Workers who have been exposed to low concentrations of ozone should be given oxygen to breathe while under the observation of trained personnel.
4. If exposure is severe, send for medical assistance immediately.

### **5Fii. Inhalation**

1. Assess the worker's breathing.
2. All unconscious workers must be placed in the drainage position (on their sides); so that fluids can drain from the airways once breathing has been restored.
3. Check pulse.
4. If breathing has ceased, start artificial respiration (rescue breathing is the most effective method) until breathing has been restored.
5. Send for medical assistance immediately.
6. If absent, begin cardiopulmonary resuscitation (CPR).

### **5Fiii. Eye Contact**

1. Effective irrigation should start immediately. Eyes should be irritated for 30 minutes by the clock with running tap water or preferably normal saline.
2. Effective irrigation must be continued while en route to the hospital.

# 5. OVERVIEW AND SAFETY PROCEDURES

## 5Fiv. Precautions

Workers with a previous cardiopulmonary (heart and lung) condition must consult their physician before working in an area in which they may be exposed to ozone. Significant alterations in cardiopulmonary functions have been documented when such workers have been exposed to low concentrations of ozone.

## 5Fv. Emergency Information Form

An emergency information form (see example below) should be filled out before operating the Ozone Generator.

**EMERGENCY INFORMATION**

**FILL IN ALL INFORMATION NOW. IF YOU DO NOT KNOW. FIND OUT BEFORE AN EMERGENCY OCCURS.**

Person Responsible for control/Evacuation \_\_\_\_\_  
Phone: \_\_\_\_\_  
Alternate: \_\_\_\_\_  
Phone#: \_\_\_\_\_

Emergency response team \_\_\_\_\_  
Phone: \_\_\_\_\_

Fire Department \_\_\_\_\_  
Phone \_\_\_\_\_

Doctor/First aid: \_\_\_\_\_  
Phone: \_\_\_\_\_

Ozone Manufacturer \_\_\_\_\_  
Phone \_\_\_\_\_

Ozone leak location \_\_\_\_\_

Location to notify in emergency situations:

| Name: | Phone |
|-------|-------|
|       |       |
|       |       |
|       |       |
|       |       |
|       |       |
|       |       |
|       |       |
|       |       |
|       |       |



## 6. WARRANTY

### Absolute Ozone® Five Years Limited Warranty

The limited warranty set forth below applies to products manufactured by Absolute Ozone® 10712 - 181 Street, Edmonton, AB., T5S 1K8, Canada, and sold by Absolute Ozone® and its authorized dealers. This limited warranty is given only to the first retail purchaser of such products and is not transferable to any subsequent owners or purchasers of such products.

Absolute Ozone® warrants that Absolute Ozone® will repair or replace, at Absolute Ozone's option, any part of such products proven to be defective in materials or workmanship within five (5) years from the date of original purchase. Parts are covered under the five (5) year warranty when and only when required operating conditions and procedures as described in this manual are performed and provided. This warranty specifically excludes any components not manufactured by Absolute Ozone® that are external to the products covered, such as pumps, air compressors, monitors, tanks, or related components.

Absolute Ozone® will assist with warranty claims for such components purchased through Absolute Ozone®; limited to the extent of the manufacturer's standard warranty.

ANY REPAIR OR REPLACEMENT WILL BE WARRANTED ONLY FOR THE BALANCE OF THE ORIGINAL FIVE (5) YEAR WARRANTY PERIOD. THIS LIMITED WARRANTY DOES NOT INCLUDE ANY OF THE FOLLOWING:

- (a) Any labor charges for troubleshooting, removal, or installation of such parts;
- (b) Any repair or replacement of such parts necessitated by faulty installation, improper operating procedures and conditions, misuse, abuse, negligence, accident, fire, flood, repair materials, and/or unauthorized accessories;
- (c) Any such products installed without regard to required local codes and accepted trade practices;
- (d) Damage caused by water passing through the unit;
- (e) Damage caused by operating below or above specified working pressure;

## 6. WARRANTY

- (f) ANY IMPLIED WARRANTY OF MERCHANTABILITY OR IMPLIED WARRANTY OF FITNESS FOR PARTICULAR PURPOSE, AND SUCH WARRANTIES ARE HEREBY DISCLAIMED; AND
- (g) ABSOLUTE OZONE® SHALL NOT BE LIABLE UNDER ANY CIRCUMSTANCES FOR LOSS OF USE OF SUCH PRODUCTS, LOST PROFITS, DIRECT DAMAGES, INDIRECT DAMAGES, CONSEQUENTIAL DAMAGES AND/OR INCIDENTAL DAMAGES

NOTE: ANY WORK PERFORMED ON ABSOLUTE OZONE PRODUCTS WITHOUT PRIOR AUTHORIZATION FROM ABSOLUTE OZONE WILL AUTOMATICALLY VOID THIS WARRANTY. ANY ABSOLUTE OZONE PRODUCT MUST BE RETURNED TO ABSOLUTE OZONE PREPAID, FOR WARRANTY EVALUATION.

THE OZONE CELL CONTAINS TAMPER-PROOF DEVICES. ANY ATTEMPT TO OPEN THE CELL WILL NOT ONLY VOID THE WARRANTY BUT WILL VOID THE POSSIBILITY OF OBTAINING ANY SERVICE BY ABSOLUTE OZONE.

### **TO OBTAIN WARRANTY SERVICE:**

Please provide the following information:

- Project, contact name, mailing address, and telephone
- Installer/Mechanical Contractor
- Serial # and date of purchase
- The date of failure
- A description of the failure
- All shipping documents should clearly state "Warranty Repair" and indicated the RMA number. Absolute Ozone is not responsible for double taxes or duties resulting from improper shipping documentation.

# 7. DIMENSIONS

## NANO®

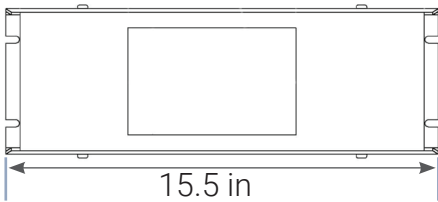

Weight: 10 lbs.

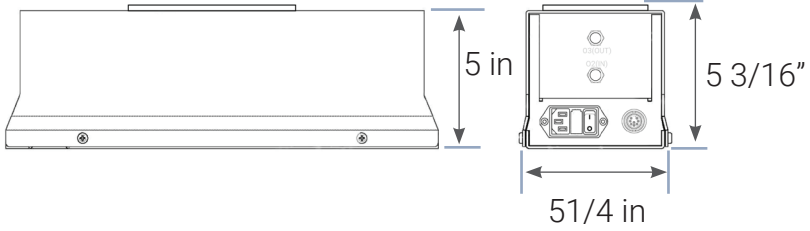

## ATLAS® Weight: 26 - 35 lbs.

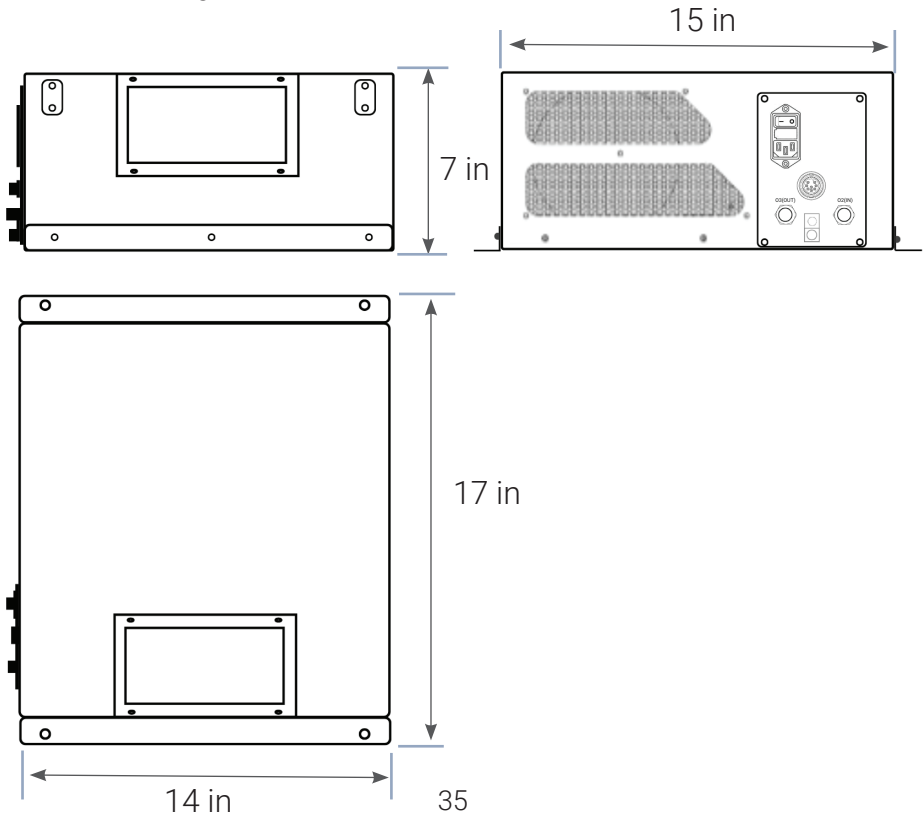

# 7. DIMENSIONS

**TITAN®**

Weight: 26 - 32 lbs.

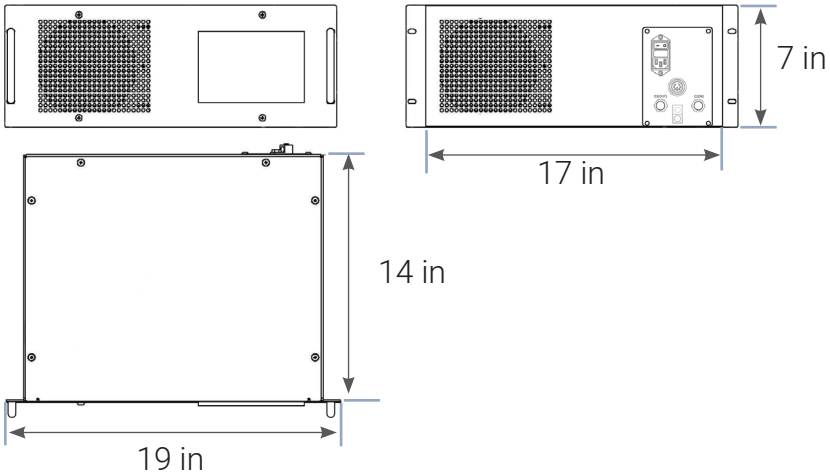

**MAGNUM®**

Weight: 70 lbs.

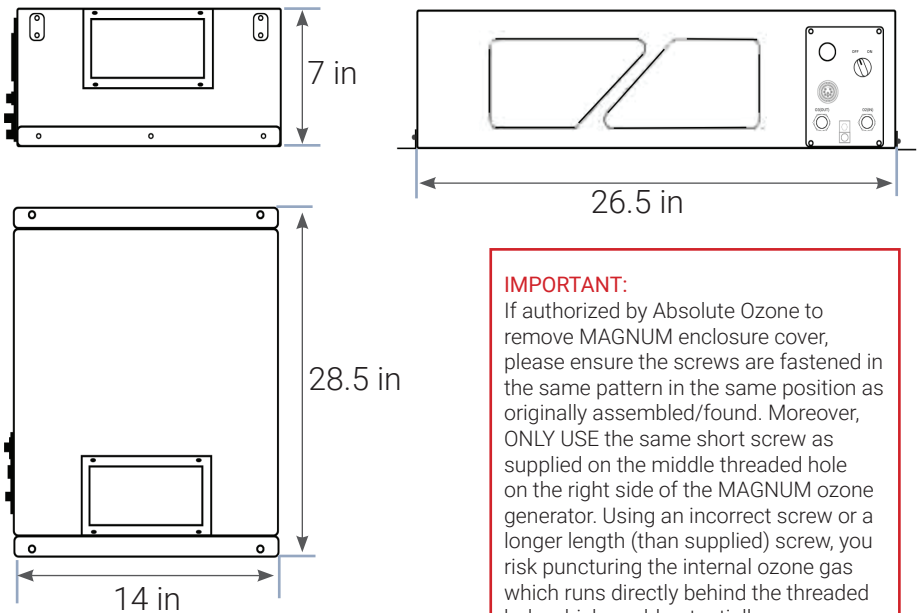

**IMPORTANT:**

If authorized by Absolute Ozone to remove MAGNUM enclosure cover, please ensure the screws are fastened in the same pattern in the same position as originally assembled/found. Moreover, ONLY USE the same short screw as supplied on the middle threaded hole on the right side of the MAGNUM ozone generator. Using an incorrect screw or a longer length (than supplied) screw, you risk puncturing the internal ozone gas which runs directly behind the threaded hole which could potentially cause a leak and would not be covered under warranty.

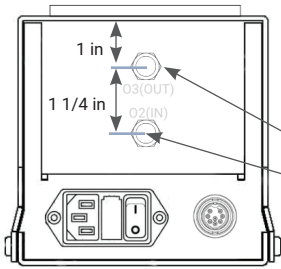

**NANO®**

Ø1/4 SS316 Compression Swagelok Type Connector

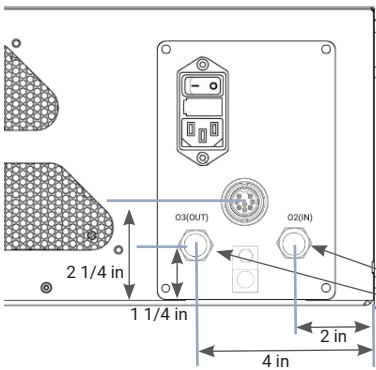

**ATLAS®**

Ø1/4 SS316 Compression Swagelok Type Connector

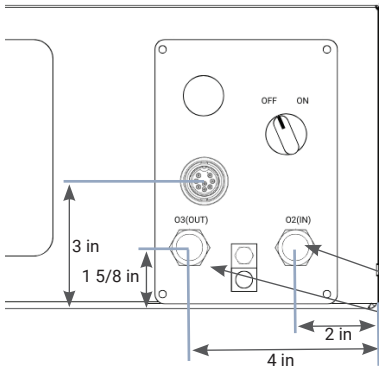

**MAGNUM®**

Ø3/8 SS316 Compression Swagelok Type Connector

## GET IN TOUCH

Our assistance to clients over the past two decades has not only provided them with the most reliable and effective ozone systems but also resulted in tremendous savings on operating expenses. Absolute Ozone generators, when installed and used correctly, require no service, repairs, or maintenance during the first 20 years of use.

**CALL US TODAY, AND LET'S DISCUSS YOUR UPCOMING OR CURRENT PROJECT**

**Phone:** 780-486-3761  
**Toll Free (US & Canada):** 1-877-486-3761  
**Email:** [Office@AbsoluteOzone.com](mailto:Office@AbsoluteOzone.com)  
**Location:** 10712-181 ST NW Edmonton  
Alberta, Canada, T5S1K8  
**Website:** [www.AbsoluteOzone.com](http://www.AbsoluteOzone.com)

Scan the code to  
download a Spanish version







**ABSOLUTE OZONE**<sup>®</sup>

[WWW.ABSOLUTEZONE.COM](http://WWW.ABSOLUTEZONE.COM)