



ABSOLUTE OZONE®

# ALD 2000 FLOOD PREVENTION DEVICE



Water back-up into the ozone generator can become a recurring problem if proper instrumentation is not installed especially if the ozone system is regularly shut-off. In order to prevent water back-up into the ozone generator from the water line and to protect your investment, we recommend to install the the ALD 2000 Flood Prevention Device, a ozonE compatible turn-key solution equipped with SS316 non-return check valves, 1/4" or 3/8" tubing connectors to effectively drain any excess water backing up into the ozone generator.

## SPECIFICATIONS

<b>Model:</b>	ALD 2000 Flood Prevention Device
<b>Body Material:</b>	Stainless Steel 304
<b>Internal/fitting Material:</b>	Stainless Steel 316
<b>Connection Sizes:</b>	1/4" or 3/8" NPT
<b>Max Operating Pressure:</b>	400 PSIG
<b>Max Operating Temperature:</b>	500F (at 400 psig)
<b>Weight:</b>	4 lbs

## INSTALLATION

The ALD 2000 should be installed after the ozone generator and flow meter on the ozone line before the injection point to prevent vaccum from backing up the water into the ozone generator

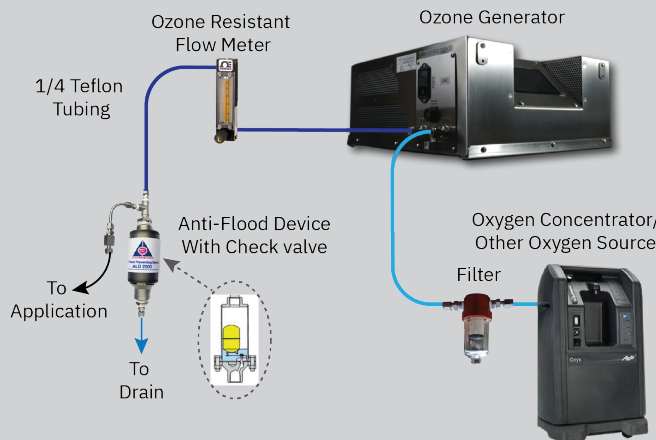

## HOW IT WORK

The ALD 2000 contains a stainless steel float-operated valve and hardened stainless steel seat and disc. When liquid enters the drainer, the float rises opening the valve allows liquid to drain out from pressurized ozone systems without the loss of pressured gas.

## DRAWINGS

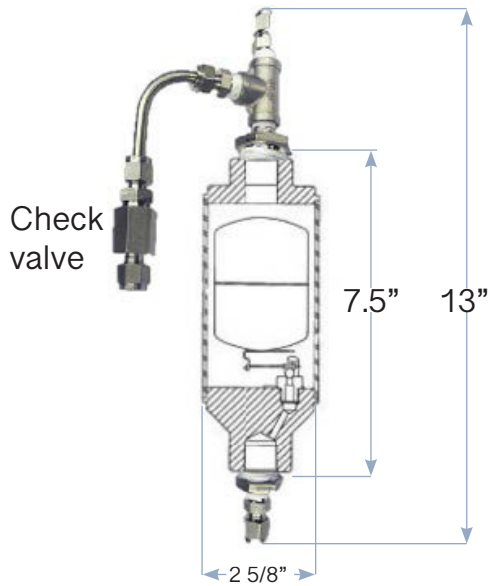

## GET IN TOUCH

Our assistance to our clients for over the past two decades not only provided them with most reliable and effective working ozone systems, but provided tremendous saving on operating expenses to them, as Absolute Ozone generators do not require any service repairs or maintenance first 20 years of use, when installed and used correctly.

### CALL US TODAY AND LET'S DISCUSS YOUR UPCOMING OR CURRENT PROJECT

**Phone:** 780-486-3761  
**Toll Free (US & Canada):** 1-877-486-3761  
**Email:** Office@AbsoluteOzone.com  
**Location:** 10712-181 ST NW Edmonton, Alberta, Canada T5S1K8  
**Website:** www.AbsoluteOzone.com