

## AIRSEP AS-B OXYGEN GENERATOR



AirSep Alpha Series Oxygen Generators produce from 20 to 5,500 cubic feet of oxygen per hour at up to 95% oxygen concentration.

When electricity and a source of compressed air is supplied, these dependable machines can provide oxygen for practically any application.

### FEATURES

- Produces oxygen from an independent compressed air source
- Microprocessor controlled
- Low operating cost
- Automatic and unattended operation
- Easy to install and maintain

### SPECIFICATIONS

- Product Flow 21 – 25 SLPM
- Product Pressure 45 – 55 psig
- Product Purity: Up to 95%
- Product Dew Point: -100°F (-73°C)
- Dimensions (WxDxH): 17x15x58 in
- Weight: 246 lb

### Feed Air Requirements

- Clean and Dry "Plant Air" (Class 5.6.4 per ISO 8573.1)
- Pressure: 90 psig minimum
- Temperature: 122°F (50°C) maximum

### Control Power Options

- 120 V ~ ±10%, 50/60 Hz
- 220 V ~ ±10%, 50/60 Hz
- 

### Required Accessories

- 60 Gallon Oxygen Receiver
- Accessory Kit KI410-1 (hoses/fittings and oxygen regulator)

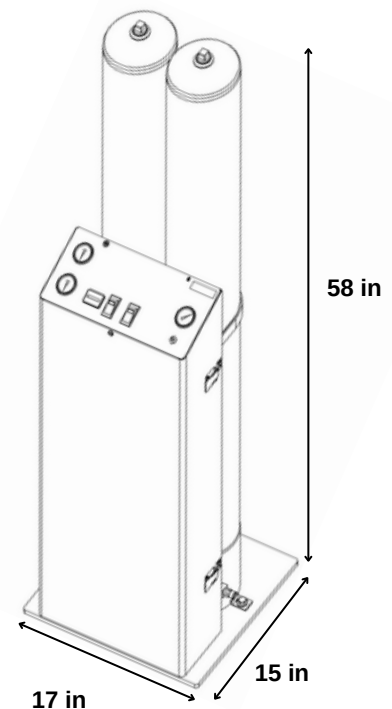

### ORDERING INFORMATION:

ABSOLUTE OZONE  
10712-181 ST NW  
EDMONTON, ALBERTA, CANADA T5S1K8  
PH: +1-780-486-3761  
E: OFFICE@ABSOLUTEZONE.COM

# AIRSEP AS-B OXYGEN GENERATOR





## AS-B PSA OXYGEN GENERATOR PARTS & ACCESSORIES

Model	Part #	Description	
AS-B	AS101-1	120 V ~ ±10%, 50/60 Hz	
	AS101-2	220 V ~ ±10%, 50/60 Hz	
Required Accessories	TA150-1	60 Gallon Oxygen Receiver	
	KI410-1	Accessories Kit (Hoses/fittings and oxygen regulator)	
Optional Accessories	TA150-2	60 GallonO2 Receiver, CE-PED	
	TA142-1	60 Gallon Air Tank, 110/120 V, 50/60 Hz	
	TA142-2	60 Gallon Air Tank, 220/240 V, 50/60 Hz	
	KI410-2	Accessories Kit (Hoses/fittings, O2 regulator and O2 filter)	
	KI474-1	Accessories Kit (10 ft stainless braided oxygen hose)	
	KI404-1	Accessories Kit (switch-over manifold for cylinder backup)	
	AN021-1	Oxygen Analyzer (Maxtec Handi)	
	AN005-1	Oxygen analyzer (Maxtec Max O2 Plus)	
	AN075-1	Oxygen Analyzer/Sensor (Maxtec Max O2 Plus)	
	FM109-0070	Flowmeter	
AS-B	AS101-11	120 V ~ ±10%, 50/60 Hz (Includes reduced size oxygen receiver)	
Mini Pack	AS101-12	220 V ~ ±10%, 50/60 Hz (Includes reduced size oxygen receiver)	
Required Accessories	KI410-1	Accessories Kit (Hoses/fittings and oxygen regulator)	
	KI410-2	Accessories Kit (Hoses/fittings, O2 regulator & O2 filter)	
Optional Accessories	KI474-1	Accessories Kit (10 ft stainless braided oxygen hose)	
	KI404-1	Accessories Kit (switch-over manifold for cylinder backup)	
	AN021-1	OxygenA nalyzer (Maxtec Handi)	
	AN005-1	Oxygen Analyzer (Maxtec Max O2 Plus)	
	AN075-1	Oxygen Analyzer/Sensor (Maxtec Max O2 Plus)	
		FM109-0070	Flowmeter

Shipping Information	AS-B	60 gal Receiver
Class	92.5	70
Commodity Class Number	8421.39.8040	7311.00.0000
Dimensions (L x W x H)	69x29x25 in	30x28x56 in
App. Gross Weight	389 lb	174 lb

**“CALL FOR PRICE”**

 +1 (780) 486 3761  
 office@absoluteozone.com